

Echelle / Scale <b>1:20</b>	<b>HELIOS 600 3 CHANNELS</b>			Créé par : XF Le 17/04/2013
				Matière
Page <b>1/4</b>	<b>FAIVRE ETS</b> 7 Rue de l'Industrie 25110 Baume-Les-Dames Tel : +333.81.84.01.32 / Fax: +333.81.84.16.15 Mail: info@faivre.fr	Ref. <b>TH63</b>	Révision	Masse <b>885.06 kg</b>
Format <b>A3</b>				Client

NON CONTRACTUAL PLAN AMENDMENTS OF TECHNICAL DATA AS WELL AS OF MEASUREMENTS AND WEIGHTS SPECIFIED IN THIS DRAWING ARE RESERVED.  
 PLAN NON CONTRACTUEL. LES COTES SONT DONNEES A TITRE INDICATIF, LA SOCIETE SE RESERVANT LE DROIT A TOUTE MODIFICATION EVENTUELLE.

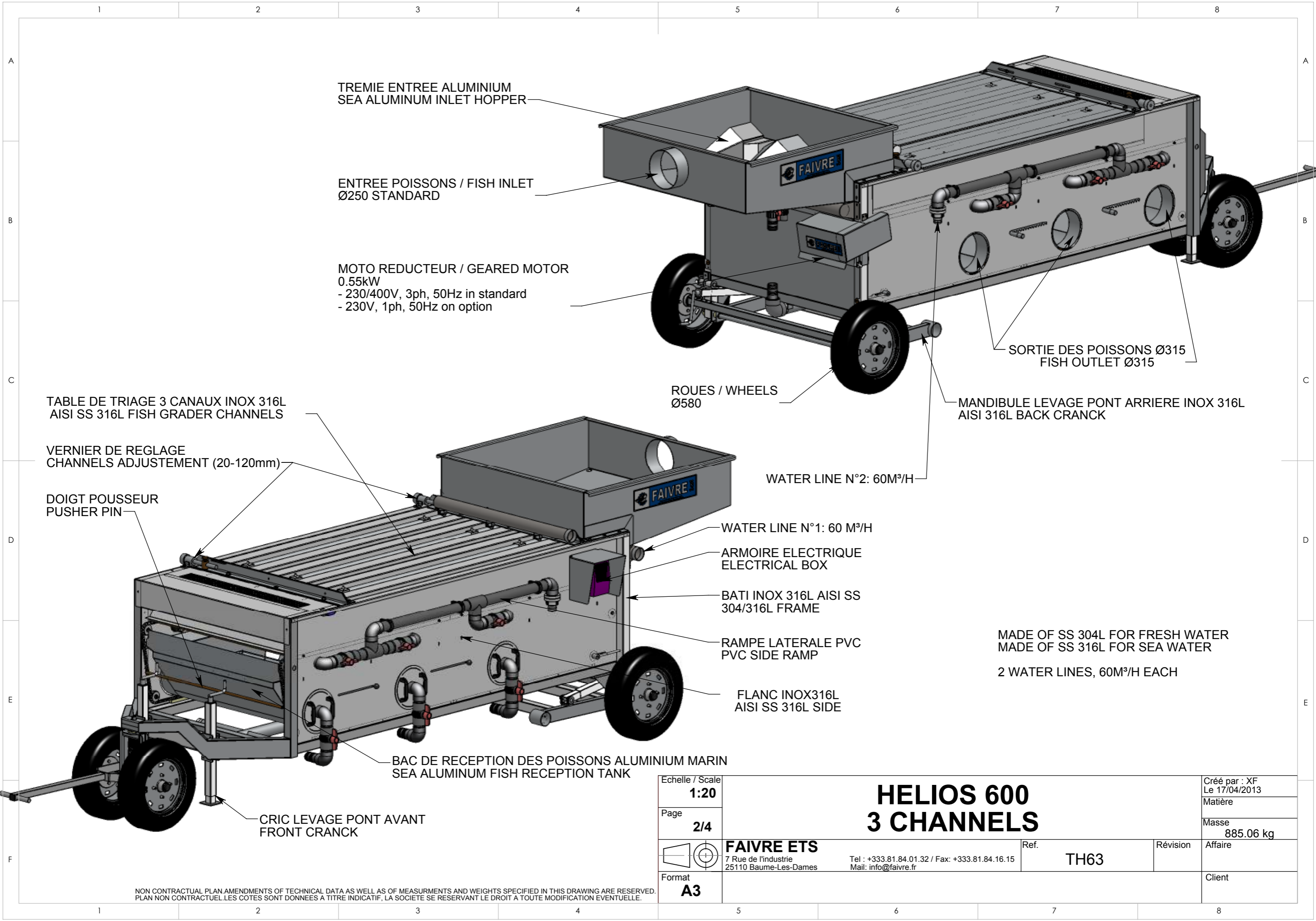

TREMIE ENTREE ALUMINIUM  
SEA ALUMINIUM INLET HOPPER

ENTREE POISSONS / FISH INLET  
Ø250 STANDARD

MOTO REDUCTEUR / GEARED MOTOR  
0.55kW  
- 230/400V, 3ph, 50Hz in standard  
- 230V, 1ph, 50Hz on option

SORTIE DES POISSONS Ø315  
FISH OUTLET Ø315

TABLE DE TRIAGE 3 CANAUX INOX 316L  
AISI SS 316L FISH GRADER CHANNELS

ROUES / WHEELS  
Ø580

MANDIBULE LEVAGE PONT ARRIERE INOX 316L  
AISI 316L BACK CRANCK

VERNIER DE REGLAGE  
CHANNELS ADJUSTEMENT (20-120mm)

WATER LINE N°2: 60M³/H

DOIGT POUSSEUR  
PUSHER PIN

WATER LINE N°1: 60 M³/H

ARMOIRE ELECTRIQUE  
ELECTRICAL BOX

BATI INOX 316L AISI SS  
304/316L FRAME

RAMPE LATERALE PVC  
PVC SIDE RAMP

MADE OF SS 304L FOR FRESH WATER  
MADE OF SS 316L FOR SEA WATER

2 WATER LINES, 60M³/H EACH

FLANC INOX316L  
AISI SS 316L SIDE

BAC DE RECEPTION DES POISSONS ALUMINIUM MARIN  
SEA ALUMINIUM FISH RECEPTION TANK

CRIC LEVAGE PONT AVANT  
FRONT CRANCK

Echelle / Scale  
**1:20**

Page  
**2/4**

Format  
**A3**

# HELIOS 600 3 CHANNELS

**FAIVRE ETS**  
7 Rue de l'Industrie  
25110 Baume-Les-Dames

Tel : +333.81.84.01.32 / Fax: +333.81.84.16.15  
Mail: info@faivre.fr

Ref. **TH63**

Révision

Créé par : XF  
Le 17/04/2013

Matière

Masse  
**885.06 kg**

Affaire

Client

NON CONTRACTUAL PLAN. AMENDMENTS OF TECHNICAL DATA AS WELL AS OF MEASUREMENTS AND WEIGHTS SPECIFIED IN THIS DRAWING ARE RESERVED.  
PLAN NON CONTRACTUEL. LES COTES SONT DONNEES A TITRE INDICATIF, LA SOCIETE SE RESERVANT LE DROIT A TOUTE MODIFICATION EVENTUELLE.