

NON CONTRACTUAL PLAN AMENDMENTS OF TECHNICAL DATA AS WELL AS OF MEASUREMENTS AND WEIGHTS SPECIFIED IN THIS DRAWING ARE RESERVED.  
 PLAN NON CONTRACTUEL. LES COTES SONT DONNEES A TITRE INDICATIF, LA SOCIETE SE RESERVANT LE DROIT A TOUTE MODIFICATION EVENTUELLE.

Echelle / Scale  
**1:20**

Page  
**3/4**



Format  
**A3**

**FAIVRE ETS**  
 7 Rue de l'Industrie  
 25110 Baume-Les-Dames

Tel : +333.81.84.01.32 / Fax: +333.81.84.16.15  
 Mail: info@faivre.fr

# HELIOS 600 3 CHANNELS

Ref. **TH63**

Révision

Créé par : XF  
 Le 17/04/2013

Matière

Masse  
**885.06 kg**

Affaire

Client

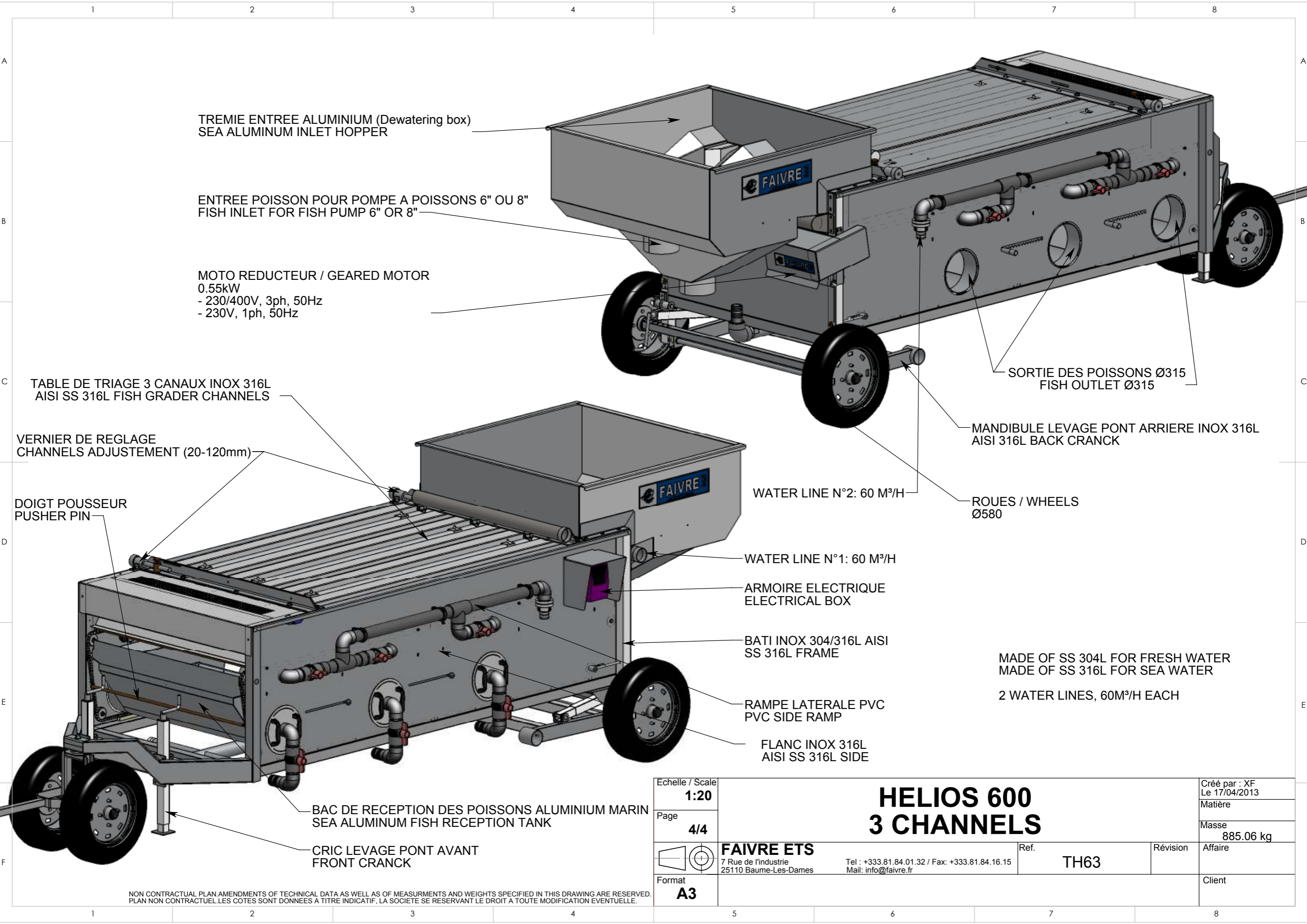

TREMIE ENTREE ALUMINIUM (Dewatering box)  
SEA ALUMINIUM INLET HOPPER

ENTREE POISSON POUR POMPE A POISSONS 6" OU 8"  
FISH INLET FOR FISH PUMP 6" OR 8"

MOTO REDUCTEUR / GEARED MOTOR  
0.55kW  
- 230/400V, 3ph, 50Hz  
- 230V, 1ph, 50Hz

TABLE DE TRIAGE 3 CANAUX INOX 316L  
AISI SS 316L FISH GRADER CHANNELS

VERNIER DE REGLAGE  
CHANNELS ADJUSTEMENT (20-120mm)

DOIGT POUSSEUR  
PUSHER PIN

BAC DE RECEPTION DES POISSONS ALUMINIUM MARIN  
SEA ALUMINIUM FISH RECEPTION TANK

CRIC LEVAGE PONT AVANT  
FRONT CRANCK

SORTIE DES POISSONS Ø315  
FISH OUTLET Ø315

MANDIBULE LEVAGE PONT ARRIERE INOX 316L  
AISI 316L BACK CRANCK

WATER LINE N°2: 60 M³/H

ROUES / WHEELS  
Ø580

WATER LINE N°1: 60 M³/H

ARMOIRE ELECTRIQUE  
ELECTRICAL BOX

BATI INOX 304/316L AISI  
SS 316L FRAME

RAMPE LATERALE PVC  
PVC SIDE RAMP

FLANC INOX 316L  
AISI SS 316L SIDE

MADE OF SS 304L FOR FRESH WATER  
MADE OF SS 316L FOR SEA WATER

2 WATER LINES, 60M³/H EACH

Echelle / Scale  
**1:20**

Page  
**4/4**

Format  
**A3**

# HELIOS 600 3 CHANNELS

**FAIVRE ETS**  
7 Rue de l'Industrie  
25110 Baume-Les-Dames

Tel : +333.81.84.01.32 / Fax: +333.81.84.16.15  
Mail: info@faivre.fr

Ref.  
**TH63**

Révision

Créé par : XF  
Le 17/04/2013

Matière

Masse  
**885.06 kg**

Affaire

Client

NON CONTRACTUAL PLAN AMENDMENTS OF TECHNICAL DATA AS WELL AS OF MEASUREMENTS AND WEIGHTS SPECIFIED IN THIS DRAWING ARE RESERVED.  
PLAN NON CONTRACTUEL. LES COTES SONT DONNEES A TITRE INDICATIF, LA SOCIETE SE RESERVANT LE DROIT A TOUTE MODIFICATION EVENTUELLE.