

PESCAMOTION

Propeller fish pump

Fish Pump

10 Series
2,5"



2,5"

Pescamotion 10

A new 2,5" (60 mm) fish pump that is light-weight, compact, convenient, and with high performance.

FAIVRE company has developed a new model of Pescamotion to transfer live fish up to 40g* (Salmonids) and up to 6g with shrimps. The Pescamotion 10 is simply the best small fish pump. Our design team worked for 12 months to develop and optimize the design of the new pump housing and its propeller.

Ideal for supplying a grader, or transferring from a tank or loading lorries.

The Pescamotion 10 pump can be easily adapted to every situation.

Hygiene and disinfection with a "Zero Retention" housing:

The Pescamotion 10 is intended for hatcheries. We designed it from the start, so that it is very easy to disinfect; this is why the fish outlet is made on the bottom of the pump housing, and not on the top. The outlet on the bottom allowed us to make a drawing of the pump body with zero water retention. Between 2 uses, the empty pump housing dries, which guarantees impeccable hygiene of the pump housing. Disinfection is also greatly facilitated with this design, making the rinsing of the pump body merely a formality.

Key benefits :

- ✓ High capacity up to 4 tons/hour
- ✓ For fish up to 40 g (Salmonids)
- ✓ Total dynamic head : 12 m
- ✓ Light and convenient : 92 kg - 445 lbs
- ✓ Remote control optional (200 m - 650 ft)
- ✓ New "Full Auto" priming system
- ✓ Free maintenance with "Direct drive system" pump

Warning : The pump performance may vary according to the height and weight of the fish.

The pump is delivered as standard with a suction cone.

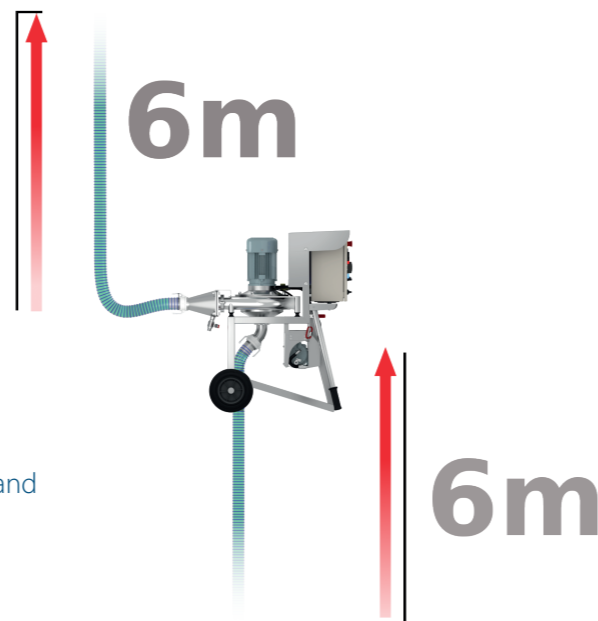
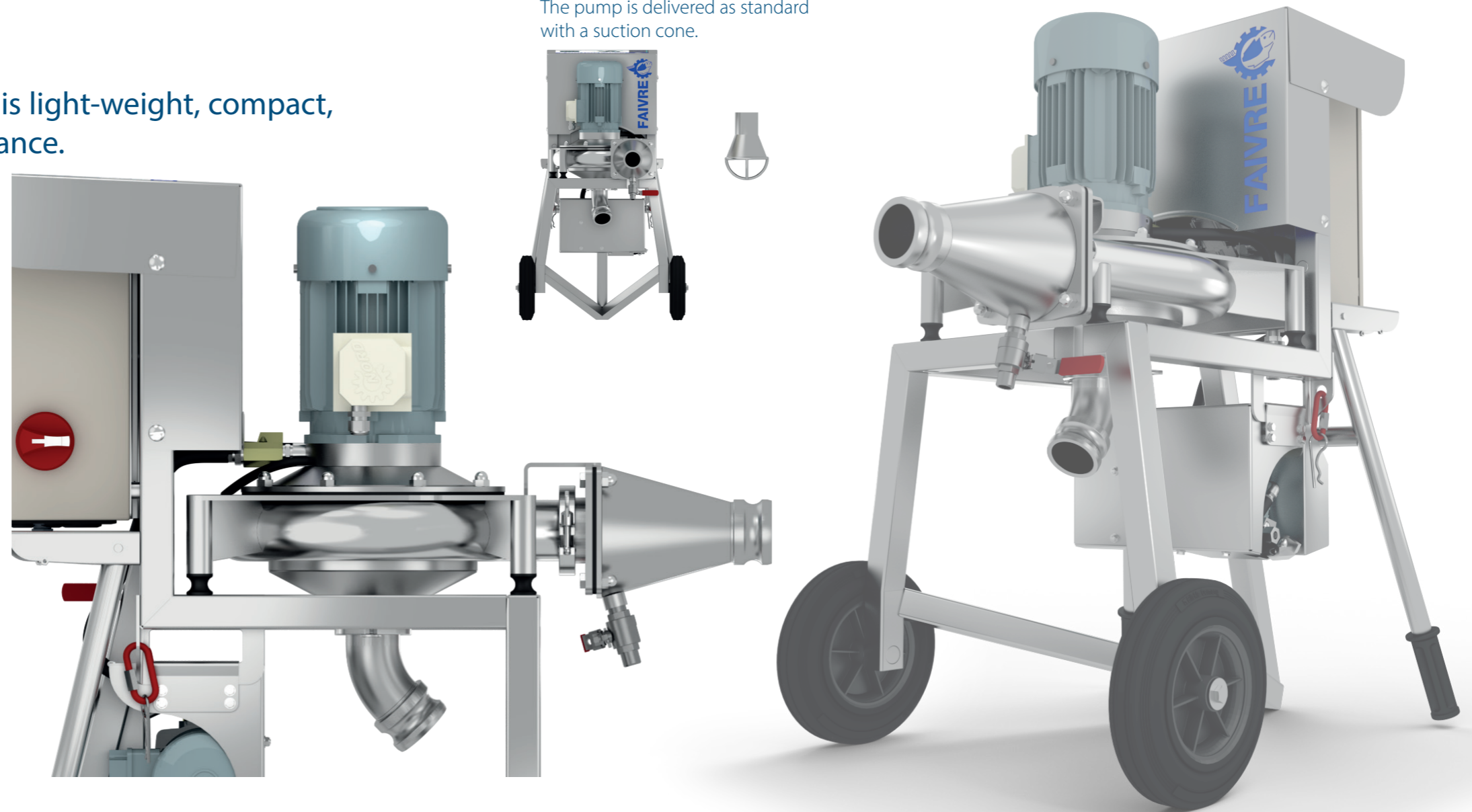

Box Control Full schneider electrique

Description

- ① Electrical main motor
- ② AISI 316L Stainless steel pump housing
- ③ Inlet fish pump (Ø 2,5" - 63 mm)
- ④ AISI 316L Stainless steel frame
- ⑤ Forklift system
- ⑥ Folding handles on hinge
- ⑦ Control box
- ⑧ Speed variator
- ⑨ Outlet fish pump (Ø 2,5" - 63 mm)



Specifications

Fish pump model	PESCAMOTION 10
Main drive motor power	1,5 kW
Main drive control	Frequency variator
Priming pump	300 W
Inlet Ø	(60 mm) 2,5" male cam lock
Outlet Ø	(60 mm) 2,5" male cam lock
Total dynamic head	12 m - 39 ft
Fish weight max.	40 g Trout/Salmon
Fish weight max.	30 g Bass
Fish weight max.	25 g Bream, Tilapia
Pump speed	Up to 1400 rpm
Water flow	42 m3/h - 184 gpm
Weight	90 kg - 445 lbs
Reference (3 x 304 - 528 V 50/60 Hz)	PH0202
Reference (3 x 180 - 264 V 50/60 Hz)	PH0203
Reference (1 x 200 - 240 V 50/60 Hz)	PH0204

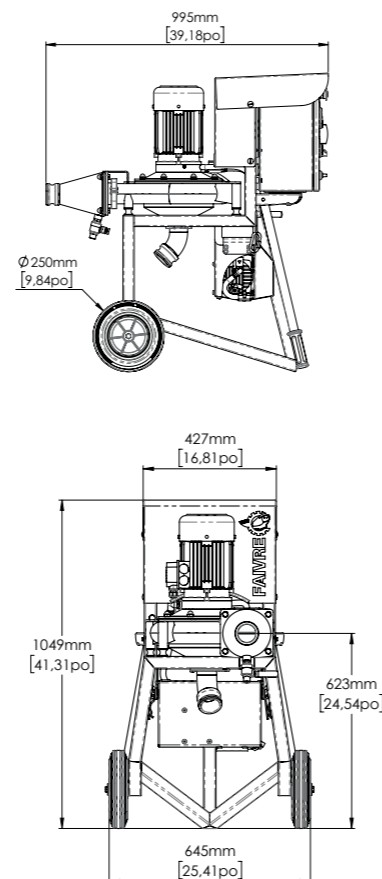

OPTIONS

Remote control

200 meters IP 67 remote control, supplied as an option. Allows a full control of the pump (stop / start, pump priming, pump motor, and speed control)
Belt clip and docking station included.
Ref. : **PH00REM2**



Pack 2,5" Starter kits pack fish pump 2,5"

(5m Inlet / 5m Outlet) cam-lock MF and Suction cone - kits of 2x5 meters of 2,5" flexible pipes Ref. : **PP0201P**

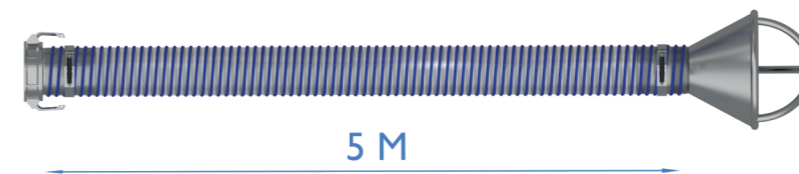

Semi - transparent, flexible hoses



Hoses Ø 2.5" (Ø 63 mm) with male and female cam lock mounted at each end of the hose.
Ref. : **PP0203FM** long. 5 m
Ref. : **PP0204FM** long. 10 m

Option parts for fish pump 2,5"



- Cam lock male (Aluminum) Ref. : **CLEA63**
- Cam lock female (Aluminum) Ref. : **CLCA63**
- Suction cone for Pescamotion 10 Ref. : **PI0251102**